



Posturepedic[®]

The
Heart & Soul
of Sleep[®]

What's included:

- Assembly Instructions
- How to care for your Sealy
- Register your Guarantee
- T&C's

Get in touch with us

customercare@sealy.co.uk

016973 20342



Welcome to Sealy

It's where sleep matters, where sleep is not just "something we all do", or "time spent in bed" but more a question of when, where, why and how we can all sleep better. It's that wholehearted commitment to the entire sleep scape that allows the Sealy Sleep Team to make mattresses that are not only different but made with love, passion and care right here in Britain.



Made in
Britain



Zero to
landfill

Assembly instructions

Divan & headboards

YOU WILL NEED



Minimum of
2 people



Wooden/
rubber mallet



Pliers



Scissors



Slotted/Pozidriv
screwdriver

UNWRAPPING

Carefully remove any cardboard protectors and all staples- this is where the pliers come in handy.

Where possible, please recycle all packaging.

ATTACHING THE FEET

Glides/Castors: Push into the corner sockets and gently tap with a wooden mallet until it is fully 'home'. Do not use a metal hammer or object as this may damage the castors or divan base (1).

Legs: To affix legs, screw bolts into the threaded holes marked 'pierce here for fittings' (2).

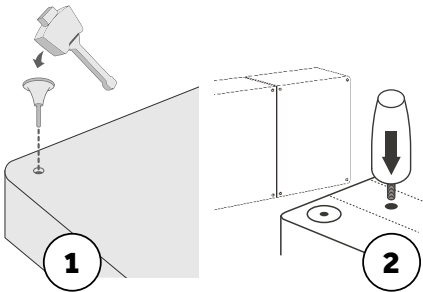

CONNECTING THE BASES

Bring the two bases together, ensuring that the black unit connectors are opposite each other. Standing where they join, lift the right hand base (approximately 10cm) whilst holding the left hand base in position, squeeze the bases together and lower the right one down ensuring the connectors interlock. Repeat on the other side.

DRAWER STORAGE

To release the drawers, please cut the temporary restraining straps and trim off any excess fabric (pic 3). Carefully remove any excess staples with pliers.

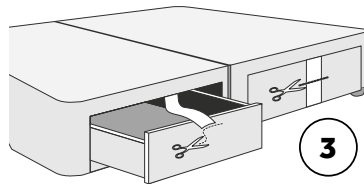

STRUTTED HEADBOARDS

(1) Place the headboard bolt into the pierce here hole. Lower the headboard into position before fully tightening the bolt. (2) Note that headboard heights can be adjusted, by amending the position of the screws on the back of the board. There are 5 different positions in which you can adjust the height of your board to allow it to sit nicely above your mattress.

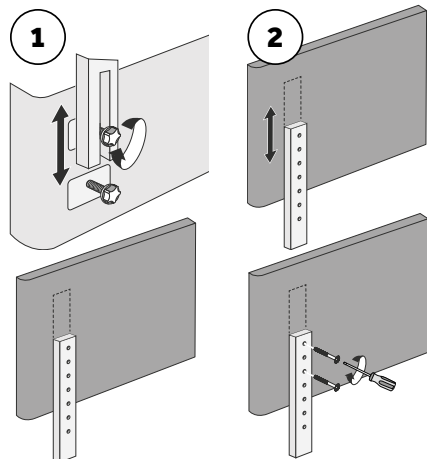

FULL HEIGHT HEADBOARDS

Carefully pierce the fabric where the stickers mark the hole in the divan.

Line up the headboard hole with the divan hole.

- (1) Thread the headboard bolt through them both and tighten into position. If additional fittings have been supplied, please use these instead of the standard fittings issued with the divan base. Pierce the divan with the bolts and screw into the base until the shorter thread is no longer visible.
- (2) Place a single plastic cap on each of the bolts and tighten until headboard is secure. Place a second plastic cap on each of the bolts to prevent them from catching*.

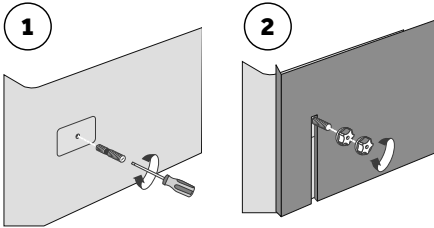

*The additional cap can also be used as a spacer between the headboard and the divan. This should only be used as a spacer if the divan drawer is restricted from opening by the headboard.

Ottomans

UNWRAPPING

1. Start by unwrapping the base and recycling the packaging.
2. Cut the strap that holds the lid in place, whilst holding the lid down so that it stays in place as you remove the packaging. Also, be sure to remove the cardboard protectors and cloth straps.
3. Carefully remove any staples.
4. With the lid raised to full height, locate and remove the wooden corner transit posts.
5. Turn base onto its side and gently hammer the four glides (feet) into the corner sockets.

ASSEMBLY

6. Turn the base onto its base then repeat on the other 1/2 base.
7. Locate the 'Pierce Here' stickers on the long inside edge of each lid, carefully pierce the fabric and make a hole large enough for the 'female' connector.
8. Locate the two drilled connecting holes on the long inside edge of the base units, (blue arrows) then pierce the fabric and make a hole large enough for the 'female' connector in all four aligned holes (two on each base).
9. Push both units together and line up.

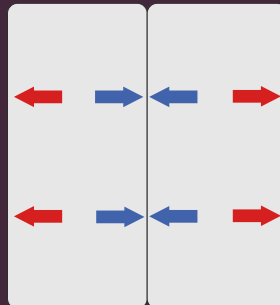

10. Apply the metal washer and insert the 'male' connector from the inside of one of the base units. Also using a metal washer, insert the 'male' connector from the inside of the other base.
11. Screw the 'male' and 'female' connectors together.
12. Repeat step eight for the second connector.
13. Insert the beige plastic hole covers in the remaining unused connector holes (red arrows).

CONNECTING THE LID

15. Place a metal washer on a 'female' connector and pass through the hole from the inside of the lid (green arrows).
16. Using a metal washer, insert the 'male' connector from the inside of the other lid.
17. Screw the 'male' and 'female' connectors together.

SAFETY WARNINGS

NOTE: It may be necessary to include one or both plastic space saver washers between the lids, to allow for adjustment of irregular floors etc.

Having completed steps one to seventeen, the bases should be assembled correctly.

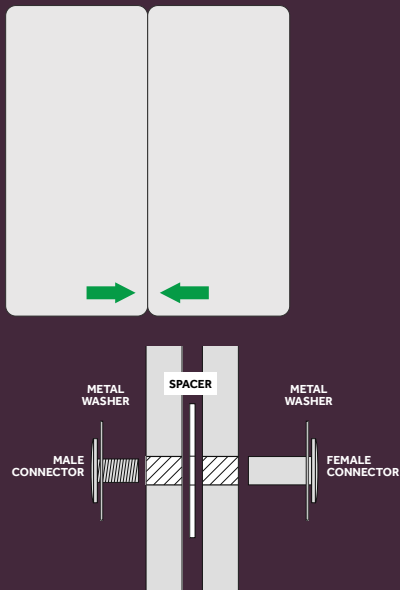

Caring for your Sealy mattress

Here at Sealy, we continue to invest in new materials, processes and techniques to ensure that every Sealy-Sleeper gets a restful and rejuvenating night's sleep.

We're so very proud of the meticulous approach we take when it comes to testing, and the standards and performance goals we set ourselves when it comes to quality and real life longevity.

That's why we have put together some tips on how best to care for your Sealy mattress.

SETTLEMENT

Some settlement is a normal occurrence with your new mattress and indicates that the upholstery layers are conforming to your body's individual contours. Any settlement less than 32 mm is considered normal. To help minimise settlement, rotate your mattress according to the schedule below.

- If your mattress is double sided please turn and rotate it 'top-to-toe' regularly.
- If your mattress is single sided rotate your mattress 'top-to-toe' so that settlement from body pressures are evenly distributed.

TURN AND ROTATE YOUR MATTRESS REGULARLY

Most of our mattresses are now single-sided so they only require rotating from end to end, which we would recommend that you do at least twice a month during the first year of use, then once a month thereafter.

Our double-sided mattress should be rotated and turned at least twice a month during the first year of use, then once a month thereafter.

NEW MATTRESS SMELL

It's quite normal for new mattresses to have a slight odour when unpackaged. Don't panic, this should pass with time. We recommend you air your mattress daily by pulling the bed covers back.

PROTECT YOUR MATTRESS

We recommend that you use a breathable mattress cover, to protect from body moisture or other liquids.

USING AN ELECTRIC BLANKET

We recommend you follow any instructions and safety precautions provided by the electric blanket manufacturer. Sealy cannot be liable for any issues that relate to the electric blanket.

DISCOLOURATION

Please be aware that extreme heat sources, such as hot water bottles and electric blankets, can cause your mattress to discolour over time.

AVOID USING DETERGENTS OR CHEMICAL CLEANERS

Using detergents or chemical cleaners on your mattress may damage the fabric and stitching.

DO NOT BEND OR ROLL YOUR MATTRESS

Please don't bend or roll your mattress as this will damage it and invalidate the guarantee.

OVERLOADING THE DRAWERS WILL CAUSE DAMAGE

If your bed base has drawers, they have been designed to take lightweight items only. Excessive weight can cause distortion or damage to the drawers.

Maximum weight:

- Mini drawers - 7kg.
- Standard drawers - 15kg.
- Our Ottoman beds have a maximum fill weight of 40kg and this should be spread evenly.

RECYCLE RESPONSIBLY

At Sealy, we care about the environment and we strive to reduce our impact on the planet as much as possible. As part of this, we ask that you recycle your mattress responsibly via your local council scheme.

Guarantee

Sealy Classics

5 Year Guarantee



Sealy Posturepedic

7 Year Guarantee



Sealy Posturepedic Exquisite

10 Year Guarantee



Scan to register your guarantee



Or visit [sealy.co.uk/register-your-guarantee](https://www.sealy.co.uk/register-your-guarantee)

In the unlikely event of material or workmanship defects within the 5 or 7 year guarantee period, we will arrange to repair or replace your Sealy product at our discretion. The guarantee will then continue from the original purchase date.

Any claims made under this guarantee must be made initially through the retailer from whom the product was purchased.

We cannot enter into any discussion with the purchaser until the retailer has inspected any alleged complaint and judged as justified. On receipt of the retailer's report, we will take the necessary action under the terms of the guarantee.

Sealy reserves the right to refuse service with any defect if:

1. The defect is due to causes other than faulty materials or workmanship.
2. The item is soiled and in an unsanitary condition.
3. Any of our Terms and Conditions are not abided by in full.

When repairing or replacing items under the guarantee, we reserve the right to substitute products or materials should the original no longer be available. This does not affect the purchaser's statutory rights.

Guarantee applicable on purchases made from 2nd April 2019.

For full T&C's, please visit www.sealy.co.uk



Love your new Sealy mattress?

Tag us on social media



Sealy UK & Ireland



@sealyuk_

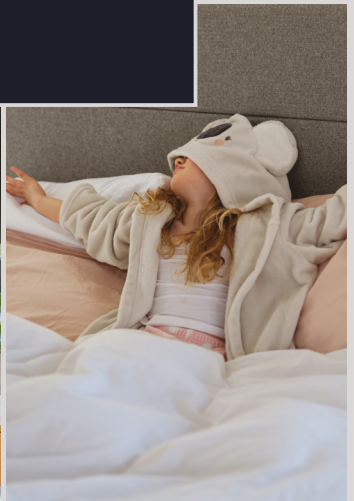
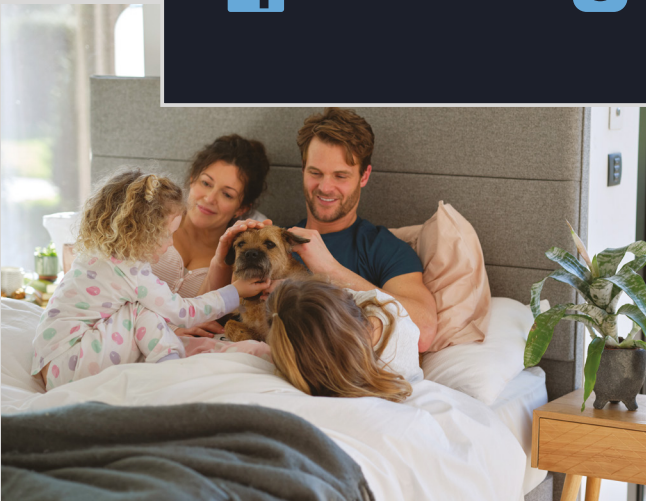
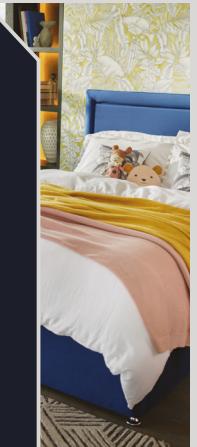

Scan to register
your guarantee

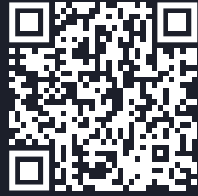

Or visit [sealy.co.uk/
register-your-sealy-guarantee](http://sealy.co.uk/register-your-sealy-guarantee)



Posturepedic[®]

Find out more
www.sealy.co.uk



MIX
Paper from
responsible sources
FSC® C023480